

Intelligent Power Module and Gate Drive Interface Optocouplers

Technical Data

HCPL-4506
HCPL-0466
HCNW4506

Features

- Performance Specified for Common IPM Applications over Industrial Temperature Range: -40°C to 100°C
- Fast Maximum Propagation Delays
 $t_{PHL} = 400 \text{ ns}$
 $t_{PLH} = 550 \text{ ns}$
- Minimized Pulse Width Distortion (PWD = 450 ns)
- 15 kV/ μs Minimum Common Mode Transient Immunity at $V_{CM} = 1500 \text{ V}$
- CTR > 44% at $I_F = 10 \text{ mA}$
- Safety Approval
 UL Recognized - 2500 V rms for 1 minute (5000 V rms for 1 minute for HCNW4506 and HCPL-4506 Option 020) per UL1577
 CSA Approved
 VDE 0884 Approved
 $-V_{IORM} = 630 \text{ V peak}$ for HCPL-4506 Option 060
 $-V_{IORM} = 1414 \text{ V peak}$ for HCNW4506
 BSI Certified (HCNW4506)

Applications

- IPM Isolation
- Isolated IGBT/MOSFET Gate Drive
- AC and Brushless DC Motor Drives
- Industrial Inverters

Description

The HCPL-4506 and HCPL-0466 contain a GaAsP LED while the HCNW4506 contains an AlGaAs LED. The LED is optically coupled to an integrated high gain photo detector. Minimized propa-

gation delay difference between devices make these optocouplers excellent solutions for improving inverter efficiency through reduced switching dead time.

An on chip 20 k Ω output pull-up resistor can be enabled by shorting output pins 6 and 7, thus eliminating the need for an external pull-up resistor in common IPM applications. Specifications and performance plots are given for typical IPM applications.

Functional Diagram

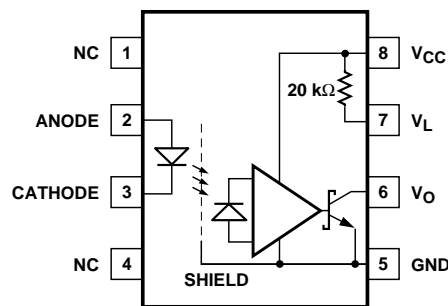

Truth Table

LED	V_O
ON	L
OFF	H

Selection Guide

Operating Temperature T_A [°C]		Single Channel Packages			
Min.	Max.	8-Pin DIP (300 Mil)	Small Outline SO-8	Widebody (400 Mil)	Hermetic*
-40	100	HCPL-4506	HCPL-0466	HCNW4506	
-55	125				HCPL-5300 HCPL-5301

*Technical data for these products are on separate HP publications.

The connection of a 0.1 μF bypass capacitor between pins 5 and 8 is recommended.

CAUTION: It is advised that normal static precautions be taken in handling and assembly of this component to prevent damage and/or degradation which may be induced by ESD.

Ordering Information

Specify Part Number followed by Option Number (if desired).

Example:

HCPL-4506#XXX

_____	020 = UL 5000 V rms/1 Minute Option*
_____	060 = VDE 0884 V _{IORM} = 630 V _{peak} Option*
_____	300 = Gull Wing Surface Mount Option†
_____	500 = Tape and Reel Packaging Option

*For HCPL-4506 only. Combination of Option 020 and Option 060 is not available.

†Gull wing surface mount option applies to through hole parts only.

Option data sheets are available. Contact your Hewlett-Packard sales representative or authorized distributor for information.

Package Outline Drawings

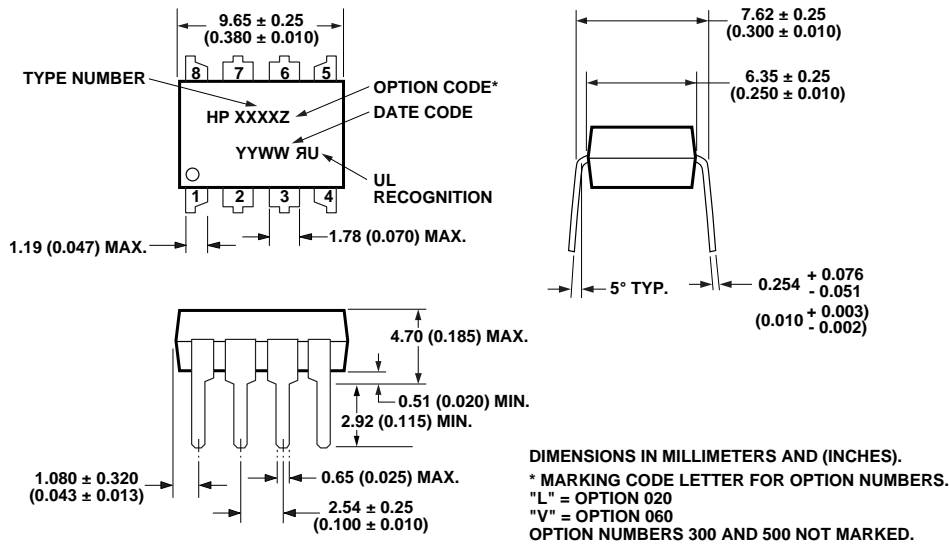

Figure 1. HCPL-4506 Outline Drawing (Standard DIP Package).

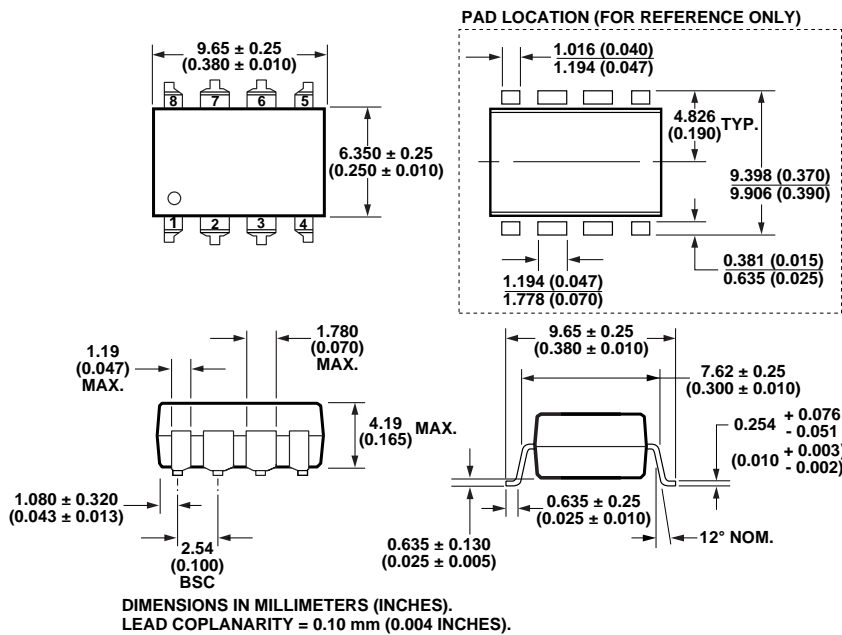

Figure 2. HCPL-4506 Gull Wing Surface Mount Option #300 Outline Drawing.

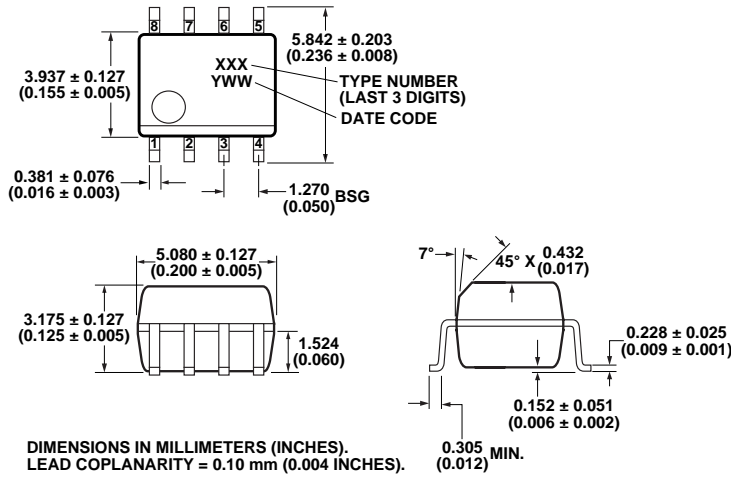

Figure 3. HCPL-0466 Outline Drawing (8-Pin Small Outline Package).

Pin Location (for reference only)

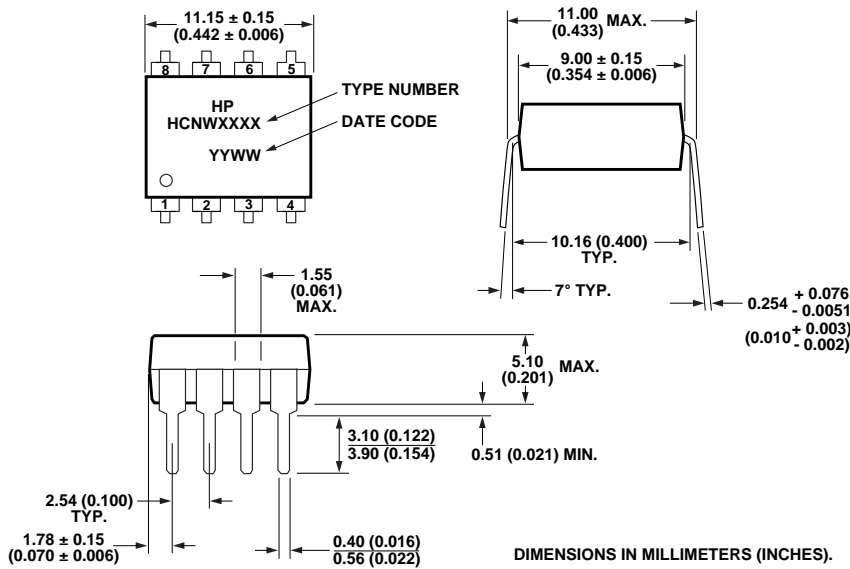

Figure 4a. HCNW4506 Outline Drawing (8-Pin Widebody Package).

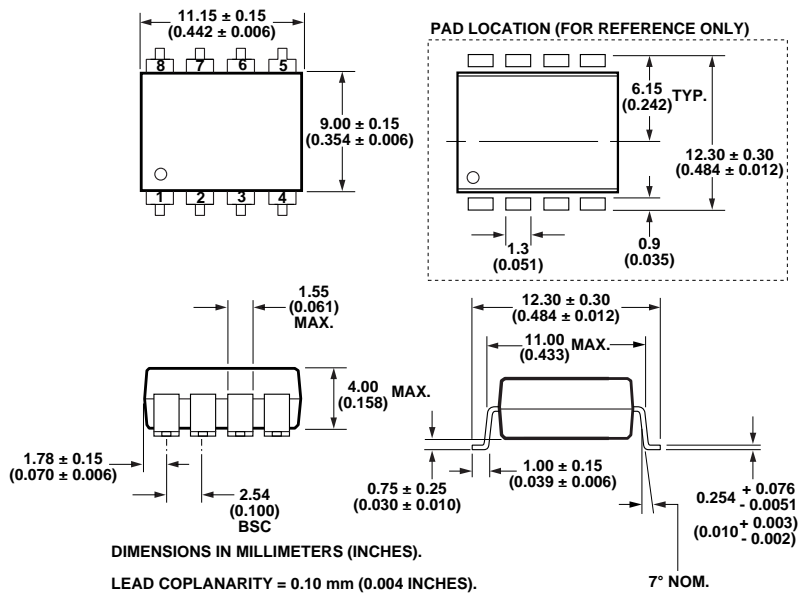
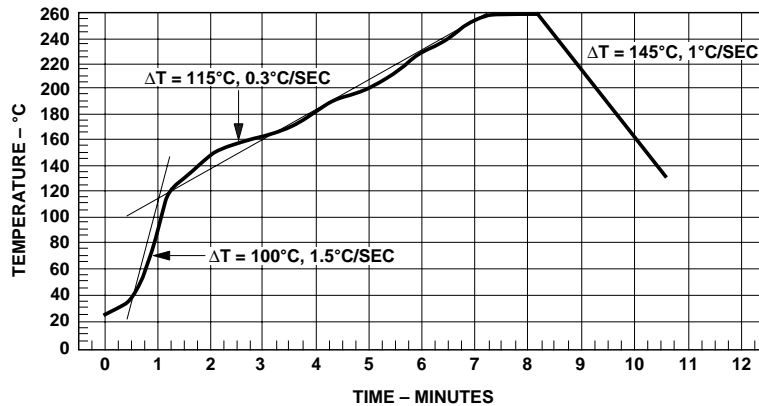

Figure 4b. HCNW4506 Outline Drawing (8-Pin Widebody Package with Gull Wing Surface Mount Option 300).

Solder Reflow Temperature Profile



Note: Use of nonchlorine activated fluxes is recommended.

Regulatory Information

The devices contained in this data sheet have been approved by the following organizations:

UL

Recognized under UL 1577, Component Recognition Program, File E55361.

CSA

Approved under CSA Component Acceptance Notice #5, File CA 88324.

VDE

Approved according to VDE 0884/06.92 (HCNW4506 and HCPL-4506 Option 060 only).

BSI

Certification according to BS451:1994 (BS EN60065:1994); BS EN60950:1992 (BS7002:1992) and EN41003:1993 for Class II applications (HCNW4506 only).

Insulation and Safety Related Specifications

Parameter	Symbol	8-Pin DIP (300 Mil) Value	SO-8 Value	Widebody (400 Mil) Value	Units	Conditions
Minimum External Air Gap (External Clearance)	L(101)	7.1	4.9	9.6	mm	Measured from input terminals to output terminals, shortest distance through air.
Minimum External Tracking (External Creepage)	L(102)	7.4	4.8	10.0	mm	Measured from input terminals to output terminals, shortest distance path along body.
Minimum Internal Plastic Gap (Internal Clearance)		0.08	0.08	1.0	mm	Through insulation distance, conductor to conductor, usually the direct distance between the photoemitter and photodetector inside the optocoupler cavity.
Minimum Internal Tracking (Internal Creepage)		NA	NA	4.0	mm	Measured from input terminals to output terminals, along internal cavity.
Tracking Resistance (Comparative Tracking Index)	CTI	200	200	200	Volts	DIN IEC 112/VDE 0303 Part 1
Isolation Group		IIIa	IIIa	IIIa		Material Group (DIN VDE 0110, 1/89, Table 1)

Option 300 - surface mount classification is Class A in accordance with CECC 00802.

**VDE 0884 Insulation Related Characteristics
(HCPL-4506 OPTION 060 ONLY)**

Description	Symbol	Characteristic	Units
Installation classification per DIN VDE 0110/1.89, Table 1 for rated mains voltage ≤ 300 V rms for rated mains voltage ≤ 450 V rms		I-IV	
		I-III	
Climatic Classification		55/100/21	
Pollution Degree (DIN VDE 0110/1.89)		2	
Maximum Working Insulation Voltage	V_{IORM}	630	V _{peak}
Input to Output Test Voltage, Method b* $V_{IORM} \times 1.875 = V_{PR}$, 100% Production Test with $t_m = 1$ sec, Partial Discharge < 5 pC	V_{PR}	1181	V _{peak}
Input to Output Test Voltage, Method a* $V_{IORM} \times 1.5 = V_{PR}$, Type and sample test, $t_m = 60$ sec, Partial Discharge < 5 pC	V_{PR}	945	V _{peak}
Highest Allowable Overvoltage* (Transient Overvoltage, $t_{ini} = 10$ sec)	V_{IOTM}	6000	V _{peak}
Safety Limiting Values (Maximum values allowed in the event of a failure, also see Figure 18, Thermal Derating curve.)			
Case Temperature	T_S	175	°C
Input Current	$I_{S,INPUT}$	230	mA
Output Power	$P_{S,OUTPUT}$	600	mW
Insulation Resistance at T_S , $V_{IO} = 500$ V	R_S	$\geq 10^9$	Ω

VDE 0884 Insulation Related Characteristics (HCNW4506 ONLY)

Description	Symbol	Characteristic	Units
Installation classification per DIN VDE 0110/1.89, Table 1 for rated mains voltage ≤ 600 V rms for rated mains voltage ≤ 1000 V rms		I-IV	
		I-III	
Climatic Classification		55/100/21	
Pollution Degree (DIN VDE 0110/1.89)		2	
Maximum Working Insulation Voltage	V_{IORM}	1414	V _{peak}
Input to Output Test Voltage, Method b* $V_{IORM} \times 1.875 = V_{PR}$, 100% Production Test with $t_m = 1$ sec, Partial Discharge < 5 pC	V_{PR}	2652	V _{peak}
Input to Output Test Voltage, Method a* $V_{IORM} \times 1.5 = V_{PR}$, Type and sample test, $t_m = 60$ sec, Partial Discharge < 5 pC	V_{PR}	2121	V _{peak}
Highest Allowable Overvoltage* (Transient Overvoltage, $t_{ini} = 10$ sec)	V_{IOTM}	8000	V _{peak}
Safety Limiting Values (Maximum values allowed in the event of a failure, also see Figure 18, Thermal Derating curve.)			
Case Temperature	T_S	150	°C
Input Current	$I_{S,INPUT}$	400	mA
Output Power	$P_{S,OUTPUT}$	700	mW
Insulation Resistance at T_S , $V_{IO} = 500$ V	R_S	$\geq 10^9$	Ω

*Refer to the front of the optocoupler section of the current catalog, under Product Safety Regulations section (VDE 0884), for a detailed description.

Note: Isolation characteristics are guaranteed only within the safety maximum ratings which must be ensured by protective circuits in application.

Absolute Maximum Ratings

Parameter	Symbol	Min.	Max.	Units
Storage Temperature	T_S	-55	125	°C
Operating Temperature	T_A	-40	100	°C
Average Input Current ^[1]	$I_{F(av)}$		25	mA
Peak Input Current ^[2] (50% duty cycle, ≤ 1 ms pulse width)	$I_{F(peak)}$		50	mA
Peak Transient Input Current (< 1 μ s pulse width, 300 pps)	$I_{F(tran)}$		1.0	A
Reverse Input Voltage (Pin 3-2)	HCPL-4506, HCPL-0466		5	Volts
	HCNW4506		3	
Average Output Current (Pin 6)	$I_{O(av)}$		15	mA
Resistor Voltage (Pin 7)	V_7	-0.5	V_{CC}	Volts
Output Voltage (Pin 6-5)	V_O	-0.5	30	Volts
Supply Voltage (Pin 8-5)	V_{CC}	-0.5	30	Volts
Output Power Dissipation ^[3]	P_O		100	mW
Total Power Dissipation ^[4]	P_T		145	mW
Lead Solder Temperature (HCPL-4506)	260°C for 10 s, 1.6 mm below seating plane			
Lead Solder Temperature (HCNW4506)	260°C for 10 s (up to seating plane)			
Infrared and Vapor Phase Reflow Temperature (HCPL-0466 and Option 300)	See Package Outline Drawings Section			

Recommended Operating Conditions

Parameter	Symbol	Min.	Max.	Units
Power Supply Voltage	V_{CC}	4.5	30	Volts
Output Voltage	V_O	0	30	Volts
Input Current (ON)	$I_{F(on)}$	10	20	mA
Input Voltage (OFF)	$V_{F(off)}$ *	-5	0.8	V
Operating Temperature	T_A	-40	100	°C

*Recommended $V_{F(off)}$ = -3 V to 0.8 V for HCNW4506.

Electrical Specifications

Over recommended operating conditions unless otherwise specified:

T_A = -40°C to +100°C, V_{CC} = +4.5 V to 30 V, $I_{F(on)}$ = 10 mA to 20 mA, $V_{F(off)}$ = -5 V to 0.8 V†

Parameter	Symbol	Min.	Typ.*	Max.	Units	Test Conditions	Fig.	Note
Current Transfer Ratio	CTR	44	90		%	$I_F = 10$ mA, $V_O = 0.6$ V		5
Low Level Output Current	I_{OL}	4.4	9.0		mA	$I_F = 10$ mA, $V_O = 0.6$ V	5,6	
Low Level Output Voltage	V_{OL}		0.3	0.6	V	$I_O = 2.4$ mA		
Input Threshold Current	I_{TH}		1.5	5.0	mA	$V_O = 0.8$ V, $I_O = 0.75$ mA	5	14
High Level Output Current	I_{OH}		5	50	μ A	$V_F = 0.8$ V	7	
High Level Supply Current	I_{CCH}		0.6	1.3	mA	$V_F = 0.8$ V, $V_O =$ Open		14
Low Level Supply Current	I_{CCL}		0.6	1.3	mA	$I_F = 10$ mA, $V_O =$ Open		14
Input Forward Voltage	V_F		1.5	1.8	V	$I_F = 10$ mA	8	
			1.6	1.85				
Temperature Coefficient of Forward Voltage	$\Delta V_F / \Delta T_A$		-1.6		mV/°C	$I_F = 10$ mA		
			-1.3					
Input Reverse Breakdown Voltage	BV_R	5			V	$I_R = 100$ μ A		
		3						
Input Capacitance	C_{IN}		60		pF	$f = 1$ MHz, $V_F = 0$ V		
			72					
Internal Pull-up Resistor	R_L	14	20	25	k Ω	$T_A = 25$ °C		10,11
Internal Pull-up Resistor Temperature Coefficient	$\Delta R_L / \Delta T_A$		0.014		k Ω /°C			

*All typical values at 25°C, $V_{CC} = 15$ V.

† $V_{F(off)}$ = -3 V to 0.8 V for HCNW4506.

Switching Specifications ($R_L = 20 \text{ k}\Omega$ External)

Over recommended operating conditions unless otherwise specified:

$T_A = -40^\circ\text{C}$ to $+100^\circ\text{C}$, $V_{CC} = +4.5 \text{ V}$ to 30 V , $I_{F(\text{on})} = 10 \text{ mA}$ to 20 mA , $V_{F(\text{off})} = -5 \text{ V}$ to 0.8 V^\dagger

Parameter	Symbol	Min.	Typ.*	Max.	Units	Test Conditions	Fig.	Note
Propagation Delay Time to Low Output Level	t_{PHL}	30	200	400	ns	$C_L = 100 \text{ pF}$	10, 12, 14-17	9, 12, 14
			100		ns	$C_L = 10 \text{ pF}$		
Propagation Delay Time to High Output Level	t_{PLH}	270	400	550	ns	$C_L = 100 \text{ pF}$	11	16
			130			$C_L = 10 \text{ pF}$		
Pulse Width Distortion	PWD		200	450	ns	$C_L = 100 \text{ pF}$		18
Propagation Delay Difference Between Any 2 Parts	$t_{\text{PLH}}-t_{\text{PHL}}$	-150	200	450	ns			15
Output High Level Common Mode Transient Immunity	$ CM_H $	15	30		kV/ μs	$I_F = 0 \text{ mA}$, $V_O > 3.0 \text{ V}$	11	16
Output Low Level Common Mode Transient Immunity	$ CM_L $	15	30		kV/ μs	$I_F = 10 \text{ mA}$ $V_O < 1.0 \text{ V}$		

Switching Specifications ($R_L = \text{Internal Pull-up}$)

Over recommended operating conditions unless otherwise specified:

$T_A = -40^\circ\text{C}$ to $+100^\circ\text{C}$, $V_{CC} = +4.5 \text{ V}$ to 30 V , $I_{F(\text{on})} = 10 \text{ mA}$ to 20 mA , $V_{F(\text{off})} = -5 \text{ V}$ to 0.8 V^\dagger

Parameter	Symbol	Min.	Typ.*	Max.	Units	Test Conditions	Fig.	Note
Propagation Delay Time to Low Output Level	t_{PHL}	20	200	400	ns	$I_{F(\text{on})} = 10 \text{ mA}$, $V_{F(\text{off})} = 0.8 \text{ V}$, $V_{CC} = 15.0 \text{ V}$, $C_L = 100 \text{ pF}$, $V_{\text{THLH}} = 2.0 \text{ V}$, $V_{\text{THHL}} = 1.5 \text{ V}$	10, 13	9-12, 14
			220	450	650			
Pulse Width Distortion	PWD		250	500	ns			18
Propagation Delay Difference Between Any 2 Parts	$t_{\text{PLH}}-t_{\text{PHL}}$	-150	250	500	ns			15
Output High Level Common Mode Transient Immunity	$ CM_H $		30		kV/ μs	$I_F = 0 \text{ mA}$, $V_O > 3.0 \text{ V}$	11	16
Output Low Level Common Mode Transient Immunity	$ CM_L $		30		kV/ μs	$I_F = 16 \text{ mA}$, $V_O < 1.0 \text{ V}$		
Power Supply Rejection	PSR		1.0		$V_{\text{P-P}}$	Square Wave, t_{RISE} , t_{FALL} > 5 ns, no bypass capacitors		14

*All typical values at 25°C , $V_{CC} = 15 \text{ V}$.

$^\dagger V_{F(\text{off})} = -3 \text{ V}$ to 0.8 V for HCNW4506.

Package Characteristics

Over recommended temperature ($T_A = -40^{\circ}\text{C}$ to 100°C) unless otherwise specified.

Parameter	Sym.	Min.	Typ.*	Max.	Units	Test Conditions		Fig.	Note
Input-Output Momentary Withstand Voltage [†]	V_{ISO}	2500			V rms	HCPL-4506 HCPL-0466	RH < 50%, t = 1 min. $T_A = 25^{\circ}\text{C}$		6, 7, 8
		5000				HCNW4506 Option 020			6, 8, 13
		5000				HCNW4506			6, 8
Resistance (Input-Output)	$R_{\text{I-O}}$		10^{12}		Ω	HCPL-4506 HCPL-0466	$V_{\text{I-O}} = 500 \text{ Vdc}$		6
		10^{12}	10^{13}			HCNW4506			
Capacitance (Input-Output)	$C_{\text{I-O}}$		0.6		pF	HCPL-4506 HCPL-0466	f = 1 MHz		6
			0.5			HCNW4506			

*All typical values at 25°C , $V_{\text{CC}} = 15 \text{ V}$.

[†]The Input-Output Momentary Withstand Voltage is a dielectric voltage rating that should not be interpreted as an input-output continuous voltage rating. For the continuous voltage rating refer to the VDE 0884 Insulation Related Characteristics Table (if applicable), your equipment level safety specification or HP Application Note 1074 entitled "Optocoupler Input-Output Endurance Voltage," publication number 5963-2203E.

Notes:

- Derate linearly above 90°C free-air temperature at a rate of $0.8 \text{ mA}/^{\circ}\text{C}$.
- Derate linearly above 90°C free-air temperature at a rate of $1.6 \text{ mA}/^{\circ}\text{C}$.
- Derate linearly above 90°C free-air temperature at a rate of $3.0 \text{ mW}/^{\circ}\text{C}$.
- Derate linearly above 90°C free-air temperature at a rate of $4.2 \text{ mW}/^{\circ}\text{C}$.
- CURRENT TRANSFER RATIO in percent is defined as the ratio of output collector current (I_{O}) to the forward LED input current (I_{F}) times 100.
- Device considered a two-terminal device: Pins 1, 2, 3, and 4 shorted together and Pins 5, 6, 7, and 8 shorted together.
- In accordance with UL 1577, each optocoupler is proof tested by applying an insulation test voltage $\geq 3000 \text{ V rms}$ for 1 second (leakage detection current limit, $I_{\text{L-O}} \leq 5 \mu\text{A}$). This test is performed before the 100% Production test shown in the VDE 0884 Insulation Related Characteristics Table, if applicable.
- For option 020, in accordance with UL 1577, each optocoupler is proof tested by applying an insulation test voltage $\geq 6000 \text{ V rms}$ for 1 second (leakage detection current limit, $I_{\text{L-O}} \leq 5 \mu\text{A}$). This test is performed before the 100% Production test for partial discharge (method b) shown in the VDE 0884 Insulation Related Characteristics Table, if applicable.
- Pulse: f = 20 kHz, Duty Cycle = 10%.
- The internal 20 k Ω resistor can be used by shorting pins 6 and 7 together.
- Due to tolerance of the internal resistor, and since propagation delay is dependent on the load resistor value, performance can be improved by using an external 20 k Ω 1% load resistor. For more information on how propagation delay varies with load resistance, see Figure 12.
- The $R_{\text{L}} = 20 \text{ k}\Omega$, $C_{\text{L}} = 100 \text{ pF}$ load represents a typical IPM (Intelligent Power Module) load.
- See Option 020 data sheet for more information.
- Use of a 0.1 μF bypass capacitor connected between pins 5 and 8 can improve performance by filtering power supply line noise.
- The difference between t_{PLH} and t_{PHL} between any two devices under the same test condition. (See IPM Dead Time and Propagation Delay Specifications section.)
- Common mode transient immunity in a Logic High level is the maximum tolerable dV_{CM}/dt of the common mode pulse, V_{CM} , to assure that the output will remain in a Logic High state (i.e., $V_{\text{O}} > 3.0 \text{ V}$).
- Common mode transient immunity in a Logic Low level is the maximum tolerable dV_{CM}/dt of the common mode pulse, V_{CM} , to assure that the output will remain in a Logic Low state (i.e., $V_{\text{O}} < 1.0 \text{ V}$).
- Pulse Width Distortion (PWD) is defined as $|t_{\text{PHL}} - t_{\text{PLH}}|$ for any given device.

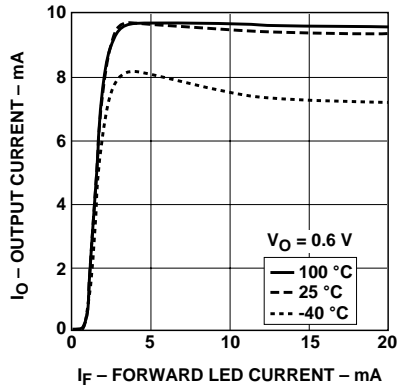

Figure 5. Typical Transfer Characteristics.

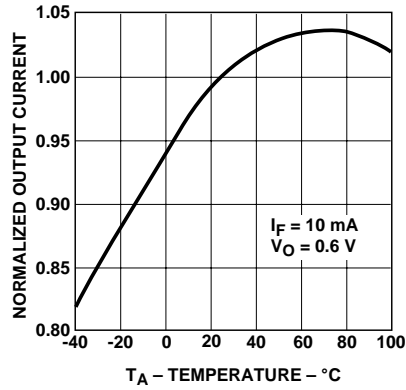

Figure 6. Normalized Output Current vs. Temperature.

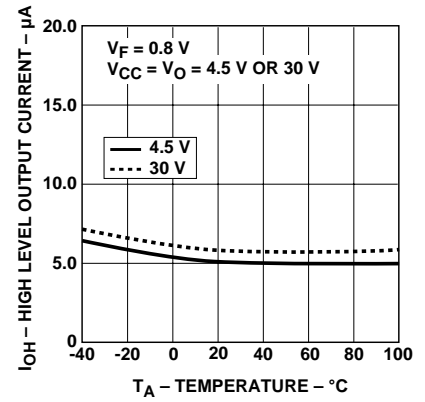

Figure 7. High Level Output Current vs. Temperature.

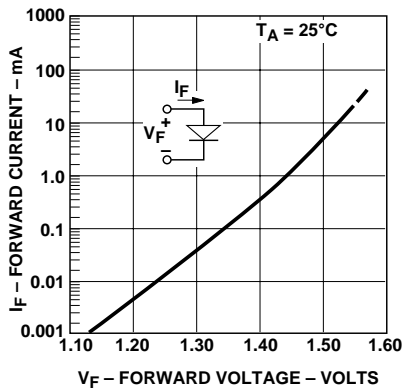

Figure 8. HCPL-4506 and HCPL-0466 Input Current vs. Forward Voltage.

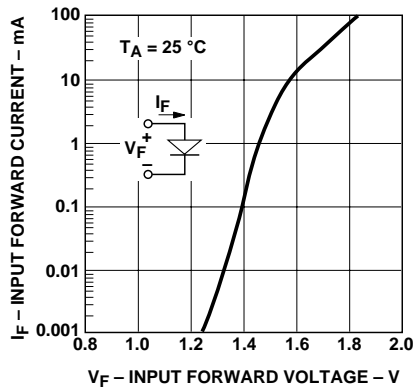

Figure 9. HCNW4506 Input Current vs. Forward Voltage.

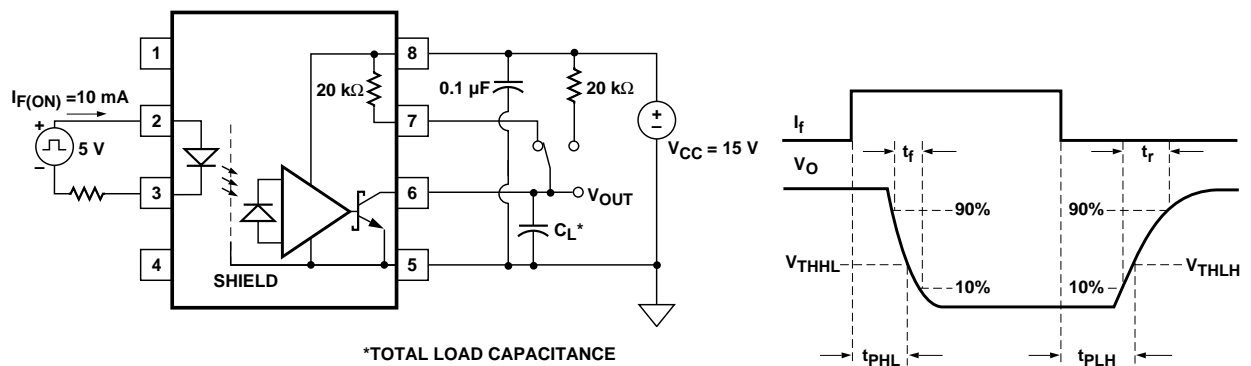

Figure 10. Propagation Delay Test Circuit.

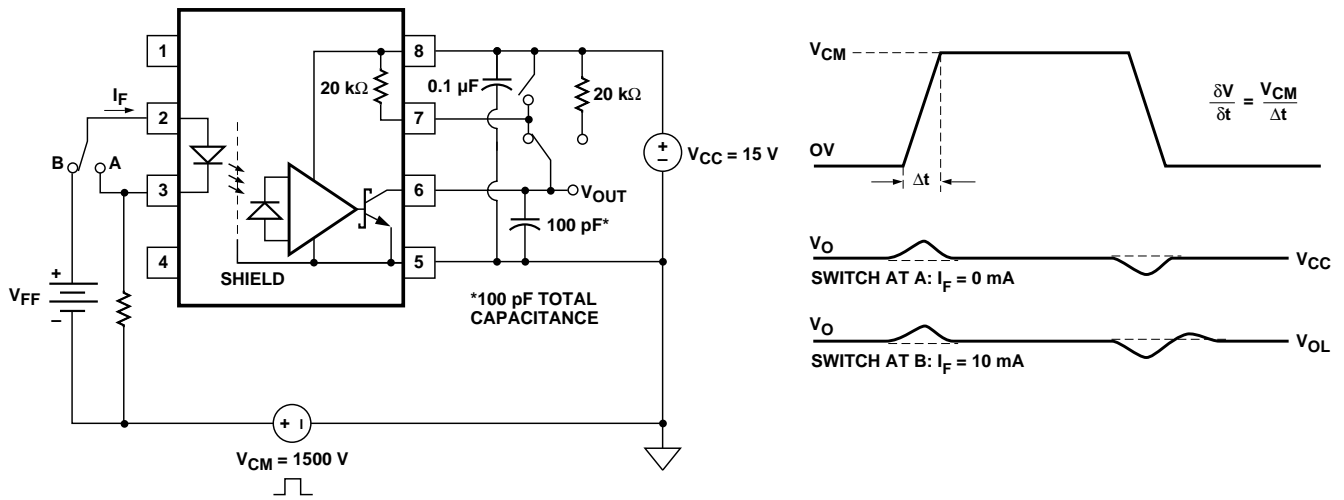

Figure 11. CMR Test Circuit. Typical CMR Waveform.

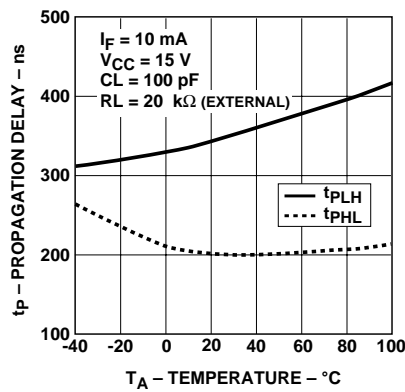

Figure 12. Propagation Delay with External 20 kΩ RL vs. Temperature.

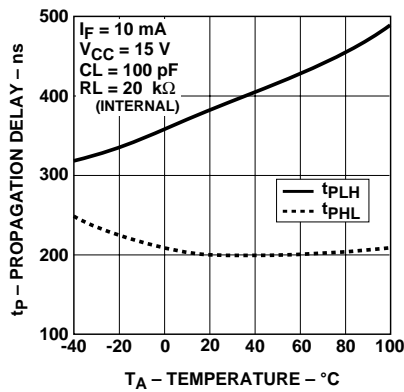

Figure 13. Propagation Delay with Internal 20 kΩ RL vs. Temperature.

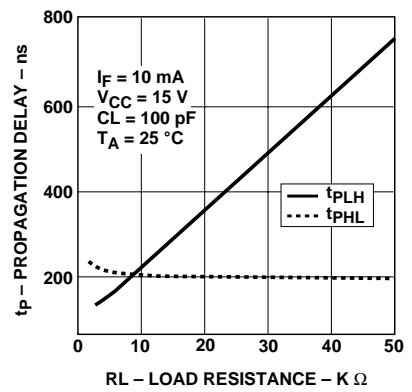

Figure 14. Propagation Delay vs. Load Resistance.

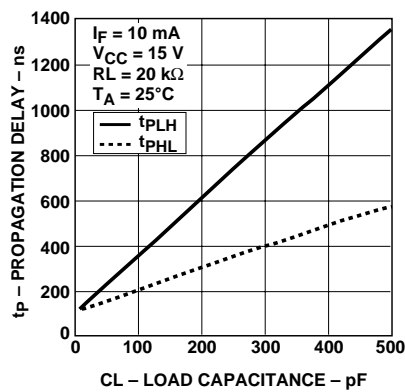

Figure 15. Propagation Delay vs. Load Capacitance.

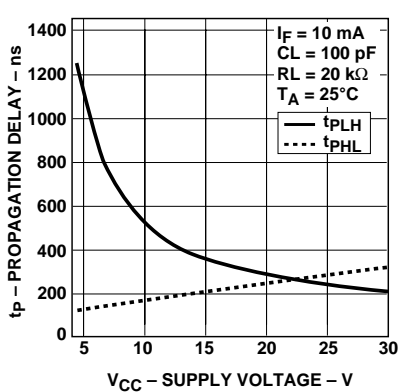

Figure 16. Propagation Delay vs. Supply Voltage.

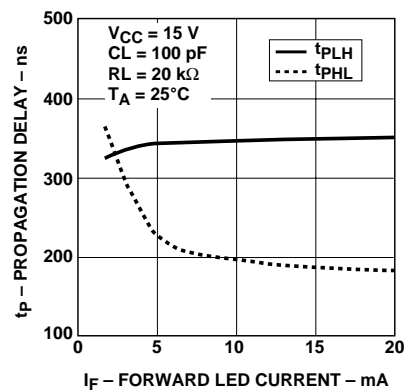

Figure 17. Propagation Delay vs. Input Current.

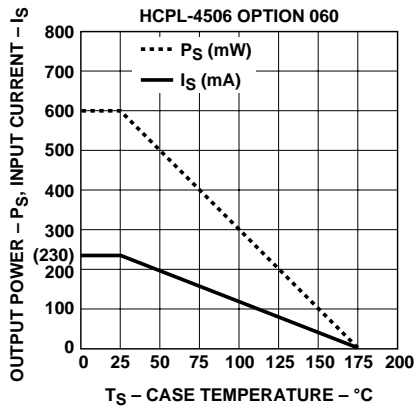

Figure 18. Thermal Derating Curve, Dependence of Safety Limiting Value with Case Temperature per VDE 0884.

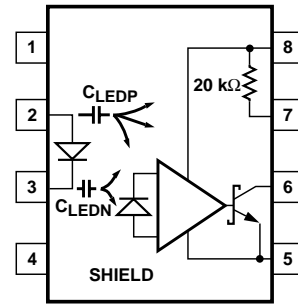
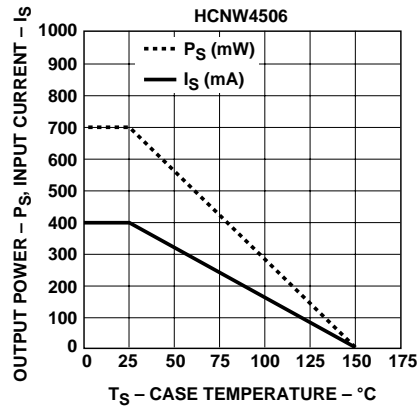

Figure 20. Optocoupler Input to Output Capacitance Model for Unshielded Optocouplers.

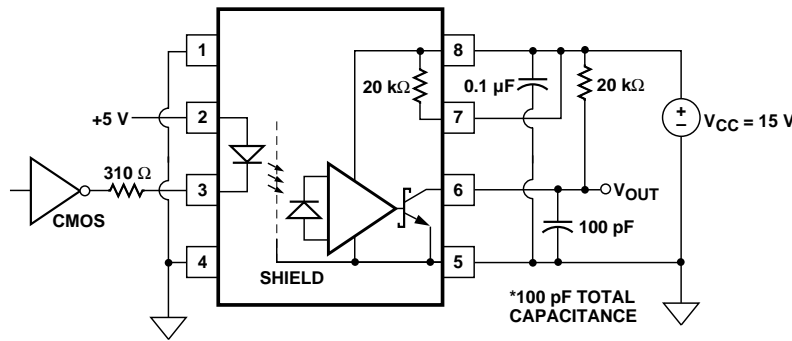

Figure 19. Recommended LED Drive Circuit.

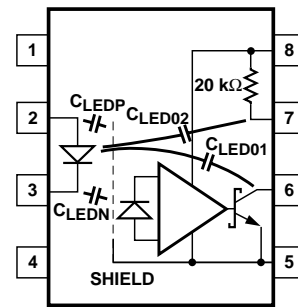

Figure 21. Optocoupler Input to Output Capacitance Model for Shielded Optocouplers.

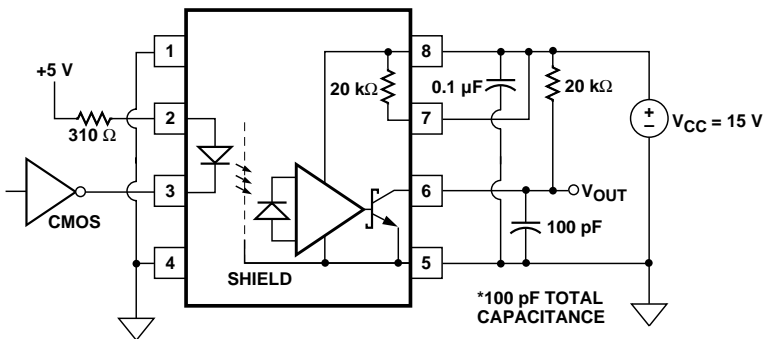

Figure 22. LED Drive Circuit with Resistor Connected to LED Anode (Not Recommended).

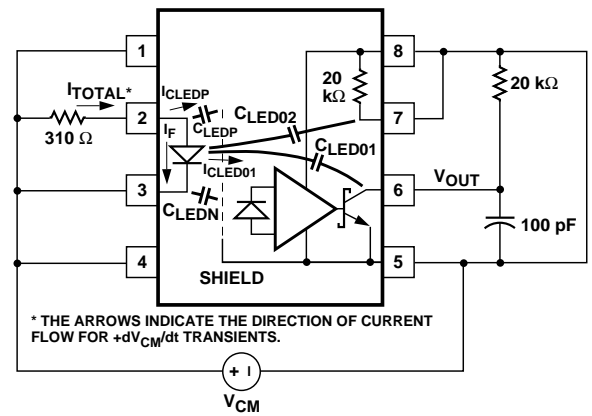

Figure 23. AC Equivalent Circuit for Figure 22 During Common Mode Transients.

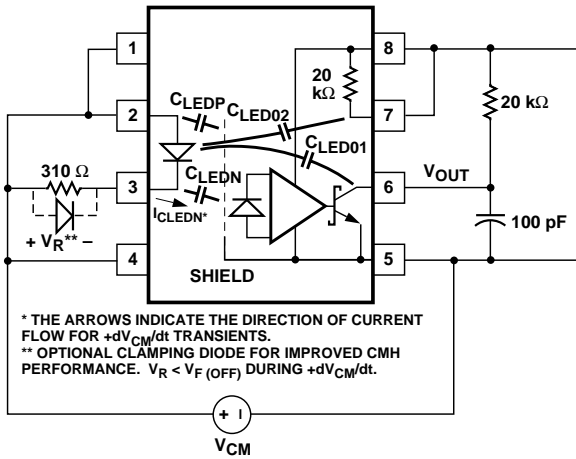

Figure 24. AC Equivalent Circuit for Figure 19 During Common Mode Transients.

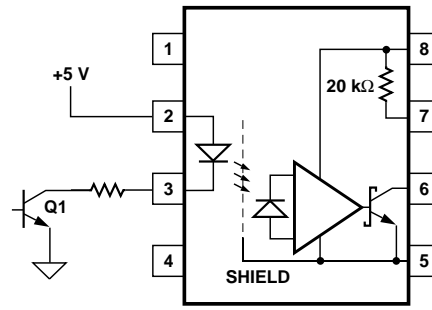

Figure 25. Not Recommended Open Collector LED Drive Circuit.

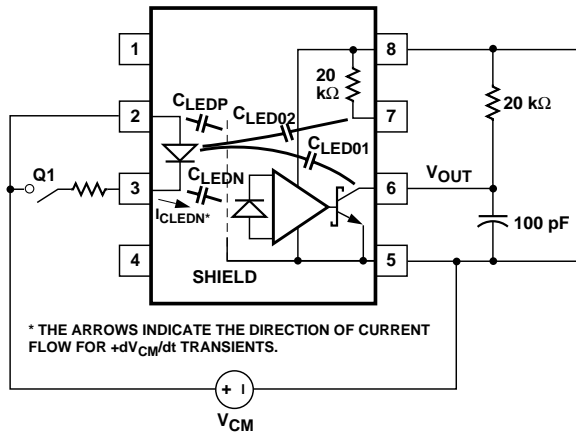

Figure 26. AC Equivalent Circuit for Figure 25 During Common Mode Transients.

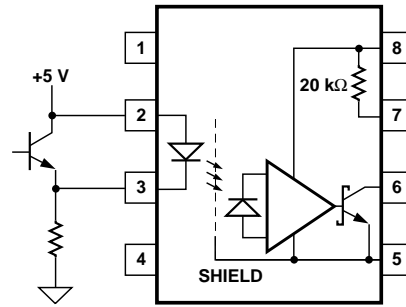

Figure 27. Recommended LED Drive Circuit for Ultra High CMR.

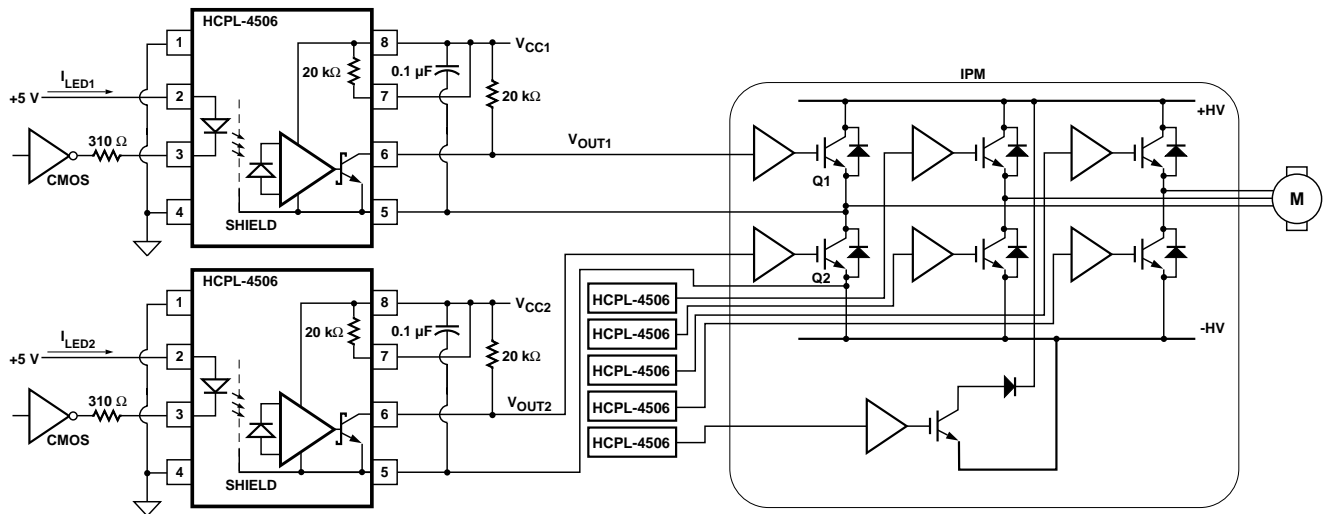
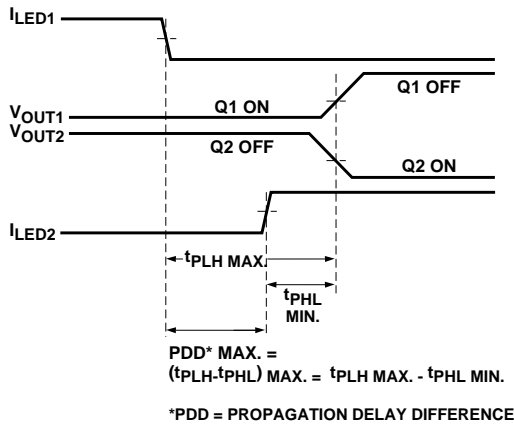
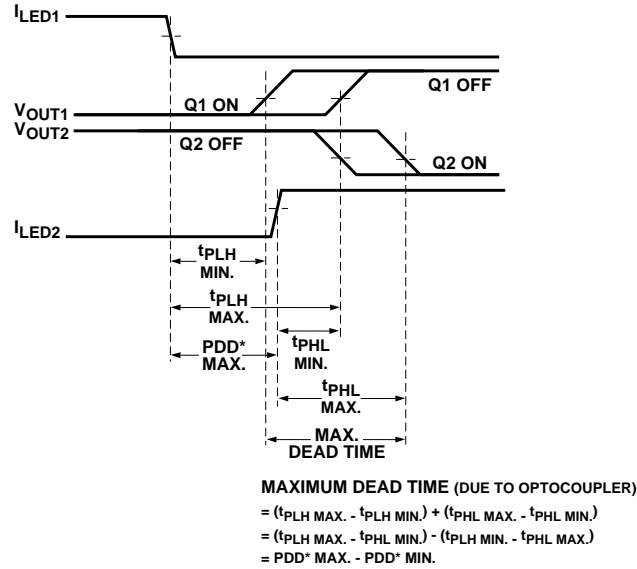

Figure 28. Typical Application Circuit.



NOTE: THE PROPAGATION DELAYS USED TO CALCULATE PDD ARE TAKEN AT EQUAL TEMPERATURES.

Figure 29. Minimum LED Skew for Zero Dead Time.



NOTE: THE PROPAGATION DELAYS USED TO CALCULATE THE MAXIMUM DEAD TIME ARE TAKEN AT EQUAL TEMPERATURES.

Figure 30. Waveforms for Dead Time Calculation.

LED Drive Circuit Considerations for Ultra High CMR Performance

Without a detector shield, the dominant cause of optocoupler CMR failure is capacitive coupling from the input side of the optocoupler, through the package, to the detector IC as shown in Figure 20. The HCPL-4506, HCPL-0466 and HCNW4506 improve CMR performance by using a detector IC with an optically transparent Faraday shield, which diverts the capacitively coupled current away from the sensitive IC circuitry. However, this shield does not eliminate the capacitive coupling between the LED and the optocoupler output pins and output ground as shown in Figure 21. This capacitive coupling causes perturbations in the LED current during common mode transients and becomes the major source of CMR failures for a shielded optocoupler. The main design objective of a high CMR LED drive circuit becomes keeping the LED in the proper state (on or off) during common mode transients. For example, the recommended application circuit

(Figure 19), can achieve 15 kV/μs CMR while minimizing component complexity. Note that a CMOS gate is recommended in Figure 19 to keep the LED off when the gate is in the high state.

Another cause of CMR failure for a shielded optocoupler is direct coupling to the optocoupler output pins through C_{LEDO1} and C_{LEDO2} in Figure 21. Many factors influence the effect and magnitude of the direct coupling including: the use of an internal or external output pull-up resistor, the position of the LED current setting resistor, the connection of the unused input package pins, and the value of the capacitor at the optocoupler output (C_L).

Techniques to keep the LED in the proper state and minimize the effect of the direct coupling are discussed in the next two sections.

CMR with the LED On (CMR_L)

A high CMR LED drive circuit must keep the LED on during common mode transients. This is

achieved by overdriving the LED current beyond the input threshold so that it is not pulled below the threshold during a transient. The recommended minimum LED current of 10 mA provides adequate margin over the maximum I_{TH} of 5.0 mA (see Figure 5) to achieve 15 kV/μs CMR. Capacitive coupling is higher when the internal load resistor is used (due to C_{LEDO2}) and an $I_F = 16$ mA is required to obtain 10 kV/μs CMR.

The placement of the LED current setting resistor effects the ability of the drive circuit to keep the LED on during transients and interacts with the direct coupling to the optocoupler output. For example, the LED resistor in Figure 22 is connected to the anode. Figure 23 shows the AC equivalent circuit for Figure 22 during common mode transients. During a $+dV_{cm}/dt$ in Figure 23, the current available at the LED anode (I_{total}) is limited by the series resistor. The LED current (I_F) is reduced from its DC value by an amount equal to the current that flows through C_{LEDP} and C_{LEDO1} . The situation is made worse

because the current through C_{LEDO1} has the effect of trying to pull the output high (toward a CMR failure) at the same time the LED current is being reduced. For this reason, the recommended LED drive circuit (Figure 19) places the current setting resistor in series with the LED cathode. Figure 24 is the AC equivalent circuit for Figure 19 during common mode transients. In this case, the LED current is not reduced during a $+dV_{cm}/dt$ transient because the current flowing through the package capacitance is supplied by the power supply. During a $-dV_{cm}/dt$ transient, however, the LED current is reduced by the amount of current flowing through C_{LEDN} . But, better CMR performance is achieved since the current flowing in C_{LEDO1} during a negative transient acts to keep the output low.

Coupling to the LED and output pins is also affected by the connection of pins 1 and 4. If CMR is limited by perturbations in the LED on current, as it is for the recommended drive circuit (Figure 19), pins 1 and 4 should be connected to the input circuit common. However, if CMR performance is limited by direct coupling to the output when the LED is off, pins 1 and 4 should be left unconnected.

CMR with the LED Off (CMR_H)

A high CMR LED drive circuit must keep the LED off ($V_F \leq V_{F(OFF)}$) during common mode transients. For example, during a $+dV_{cm}/dt$ transient in Figure 24, the current flowing through C_{LEDN} is supplied by the parallel combination of the LED and series resistor. As long as the voltage developed across the resistor is less than $V_{F(OFF)}$ the LED will remain off and no common mode failure will occur. Even if the LED momentarily turns on, the 100 pF capacitor from pins 6-5 will keep the output from dipping below the threshold. The recommended LED drive circuit (Figure 19) provides about 10 V of margin between the lowest optocoupler output voltage and a 3 V IPM threshold

during a 15 kV/ μ s transient with $V_{CM} = 1500$ V. Additional margin can be obtained by adding a diode in parallel with the resistor, as shown by the dashed line connection in Figure 24, to clamp the voltage across the LED below $V_{F(OFF)}$.

Since the open collector drive circuit, shown in Figure 25, cannot keep the LED off during a $+dV_{cm}/dt$ transient, it is not desirable for applications requiring ultra high CMR_H performance. Figure 26 is the AC equivalent circuit for Figure 25 during common mode transients. Essentially all the current flowing through C_{LEDN} during a $+dV_{cm}/dt$ transient must be supplied by the LED. CMR_H failures can occur at dV/dt rates where the current through the LED and C_{LEDN} exceeds the input threshold. Figure 27 is an alternative drive circuit which does achieve ultra high CMR performance by shunting the LED in the off state.

IPM Dead Time and Propagation Delay Specifications

The HCPL-4506, HCPL-0466 and HCNW4506 include a Propagation Delay Difference specification intended to help designers minimize "dead time" in their power inverter designs. Dead time is the time period during which both the high and low side power transistors (Q1 and Q2 in Figure 28) are off. Any overlap in Q1 and Q2 conduction will result in large currents flowing through the power devices between the high and low voltage motor rails.

To minimize dead time the designer must consider the propagation delay characteristics of the optocoupler as well as the characteristics of the IPM IGBT gate drive circuit. Considering only the delay characteristics of the optocoupler (the characteristics of the IPM IGBT gate drive circuit can be analyzed in the same way) it is important to know the minimum and maximum turn-on (t_{PHL}) and turn-off (t_{PLH}) propagation delay

specifications, preferably over the desired operating temperature range.

The limiting case of zero dead time occurs when the input to Q1 turns off at the same time that the input to Q2 turns on. This case determines the minimum delay between LED1 turn-off and LED2 turn-on, which is related to the worst case optocoupler propagation delay waveforms, as shown in Figure 29. A minimum dead time of zero is achieved in Figure 29 when the signal to turn on LED2 is delayed by ($t_{PLH\ max} - t_{PHL\ min}$) from the LED1 turn off. Note that the propagation delays used to calculate PDD are taken at equal temperatures since the optocouplers under consideration are typically mounted in close proximity to each other. (Specifically, $t_{PLH\ max}$ and $t_{PHL\ min}$ in the previous equation are not the same as the $t_{PLH\ max}$ and $t_{PHL\ min}$ over the full operating temperature range, specified in the data sheet.) This delay is the maximum value for the propagation delay difference specification which is specified at 450 ns for the HCPL-4506, HCPL-0466 and HCNW4506 over an operating temperature range of -40°C to 100°C .

Delaying the LED signal by the maximum propagation delay difference ensures that the minimum dead time is zero, but it does not tell a designer what the maximum dead time will be. The maximum dead time occurs in the highly unlikely case where one optocoupler with the fastest t_{PLH} and another with the slowest t_{PHL} are in the same inverter leg. The maximum dead time in this case becomes the sum of the spread in the t_{PLH} and t_{PHL} propagation delays as shown in Figure 30. The maximum dead time is also equivalent to the difference between the maximum and minimum propagation delay difference specifications. The maximum dead time (due to the optocouplers) for the HCPL-4506, HCPL-0466 and HCNW4506 is 600 ns (= 450 ns - (-150 ns)) over an operating temperature range of -40°C to 100°C .